

User Instructions - FCP Door Jamb Anchor - Part #1785

This document is intended to meet the Manufacturer's Instruction requirements as stated by ANSI Z359.1, and should be used as part of an employee training program as required by OSHA.



ATTENTION: This product serves as part of a fall protection system. All users must read, understand, and follow the manufacturer's instructions for each and every component of the system. All instructions must be followed for proper application, installation, use, and maintenance of this product. Changing the product, misuse of the product, or failure to follow instructions may result in serious injury or death.

If you have any questions concerning the application, installation, use, or maintenance of this product, please contact FrenchCreek Production.

Description: The FCP Door Jam Anchor is designed to be used as a temporary anchor that mounts in door or window openings. Applications include construction, wall openings, emergency and rescue situations and more.

APPLICATIONS

PURPOSE: The Door Jamb Anchor is an anchorage connector for a personal fall arrest system, designed to be temporarily installed in a door or window opening.

LIMITATIONS: The following application limitations must be considered before using this equipment:

OPENING SIZES: The Door Jamb Anchor may be installed in jambs with opening sizes ranging from 20 in. to 50 in. wide.

CAPACITY: This equipment is designed for use by persons with a combined weight (clothing, tools, etc.) of no more than 310 lbs. (141 kg). No more than one personal protective system may be connected to this equipment at one time.

PERSONAL FALL ARREST SYSTEM: The personal fall arrest system used with this equipment must meet the requirements specified in section 2.1.

FREE FALL: Personal fall arrest systems used with this equipment must be rigged to limit the free fall to a maximum of 6 feet when possible, as required by OSHA. The maximum free fall must always be within the manufacturer's free fall capacity of the system components used to arrest the fall. See section 2.1 and connecting subsystem manufacturer's instructions for more information.

SWING FALLS: Swing fall occur when the anchorage point is not directly above or below the point where a fall occurs. The force of striking and object in a swing fall may cause serious injury or death. Minimize swing falls by working as close as possible. Do not permit a swing fall if injury could occur. Swing falls will significantly increase the clearance required when a self retracting lifeline or other variable length connecting subsystem is used.

FALL CLEARANCE: There must be sufficient clearance below the user to arrest a fall before the user strikes the ground or other obstruction. The clearance required is dependent on the following factors:

- Elevation of Door Jamb Anchor
- Length of connecting subsystem
- Deceleration distance
- Movement of harness attachment element (sliding D-ring)
- Worker height
- Free fall distance

See personal fall arrest system manufacturer's instructions for more information.

WORK ZONE: (See Following Diagrams) **DO NOT extend your work zone more than 30 degrees from either side of the anchorage point. DO NOT use the door jamb anchor in such a way that it can be loaded at an angle above the level of the anchorage point. NEVER climb above the anchor point.**

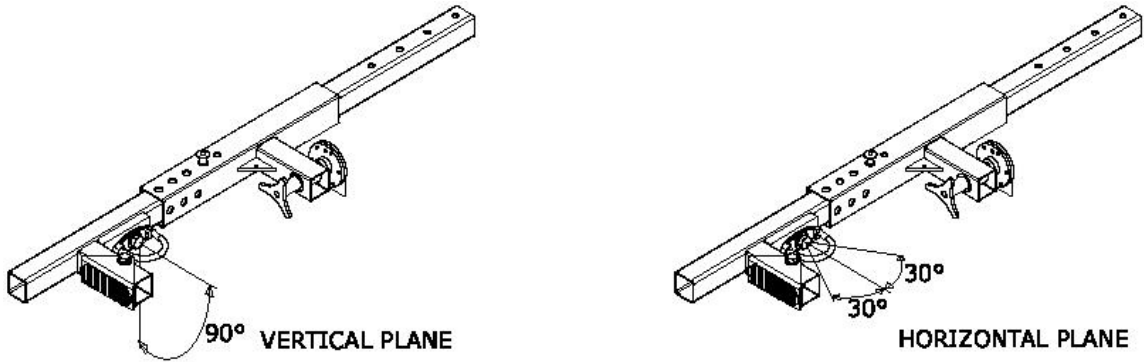

ENVIRONMENTAL HAZARDS: Use of this equipment in areas with environmental hazards may require additional precautions to reduce the possibility of injury to the user or damage to the equipment. Hazards may include, but are not limited to; heat, chemicals, corrosive environments, high voltage power lines, gases, moving machinery, and sharp edges. Contact FrenchCreek if you have questions about using this equipment where environmental hazards exist.

SYSTEM REQUIREMENTS

PERSONAL FALL ARREST SYSTEM: The Door Jamb Anchor is designed for use with FCP approved components or subsystems. Use of this equipment with non-approved components may result in incompatibility between equipment, and could affect the reliability and safety of the complete system. Personal fall arrest systems used with this equipment must meet applicable OSHA, state, federal, and ANSI requirements. A full body harness must be worn by the worker when connected to the Door Jamb Anchor. As required by OSHA, the personal fall arrest system must be capable of arresting a worker's fall with a maximum arresting force no greater than 1,800 lbs., and where possible, limit the free fall distance to 6 ft. or less. If the maximum free fall distance of 6 ft (1.83 m) must be exceeded, the employer must be able to document, based on test data, that the maximum permissible arresting forces will not be exceeded, and that the personal fall arrest system will function properly.

When a free fall greater than 6 feet is possible, it is necessary to use a personal fall arrest system incorporating an energy absorber designed specifically for this application. FCP manufactures multiple shock absorbing lanyards specifically designed for this application. Contact FCP for product details.

COMPATIBILITY OF COMPONENTS: FrenchCreek equipment is designed for use with FrenchCreek approved components and subsystems only. Substitutions or replacements made with non-approved components or subsystems may jeopardize compatibility of equipment and may affect the safety and reliability of the complete system.

CONNECTORS/CONNECTIONS: Connectors are considered to be compatible with connecting elements when they have been designed to work together in such a way that their sizes and shapes do not cause their gate mechanisms to inadvertently open regardless of how they become oriented. Connectors (hooks, carabiners, and D-rings) must be capable of supporting at least 5,000 lbs. Connectors must be compatible with the anchorage or other system components. Do not use equipment that is not compatible. Non-compatible connectors may unintentionally disengage. Connectors must be compatible in size, shape, and strength.

Self locking snap hooks and carabiners are required by ANSI Z359.1, OSHA, and CSA Z259.12. Only use connectors that are suitable to each application. Ensure all connections are compatible in size, shape and strength. Do not use equipment that is not compatible. Ensure all connectors are fully closed and locked. Connectors (snap hooks and carabiners) are designed to be used only as specified in each product's user's instructions. Connectors should not be connected:

- A. To a D-ring to which another connector is attached.
- B. In a manner that would result in a load on the gate.
- C. In a false engagement, where features that protrude from the snap hook or carabiner catch on the anchor and without visual confirmation seems to be fully engaged to the anchor point.
- D. To each other.
- E. Directly to webbing or rope lanyard or tie-back (unless the manufacturer's instructions for both the lanyard and connector specifically allows such a connection.)
- F. To any object which is shaped or dimensioned such that the snap hook or carabiner will not close and lock, or that roll-out could occur.

ANCHORAGE STRENGTH: Door Jamb Anchors installed for fall arrest applications must be attached to a door or window opening by the personal fall arrest system when in use of at least; (A) 3,600 lbs. when certification exists, or (B) 5,000 lbs in the absence of certification. Per OSHA 1926.500 and 1910.66: Anchorages used for attachment of a personal fall arrest system shall be independent of any anchorage being used to support or suspend platforms, and must support at least 5,000 lbs per user attached; or be designed, installed, and used as part of a complete personal fall arrest system which maintains a safety factor of at least two, and is supervised by a qualified person.

INSTALLATION AND USE

WARNING: Do not alter or intentionally misuse this equipment. Consult FrenchCreek Production when using this equipment in combination with components or subsystems other than those described in this manual. Some subsystem and component combinations may interfere with the operation of this equipment. Use caution when using this equipment around moving machinery, and sharp edges.

WARNING: Consult your doctor if there is reason to doubt your fitness to safely absorb the shock from a fall. Age and fitness seriously affect a worker's ability to withstand fall. Pregnant women or minors should not use this equipment.

BEFORE USE: This equipment must be carefully inspected according to the inspection criteria before each and every use.

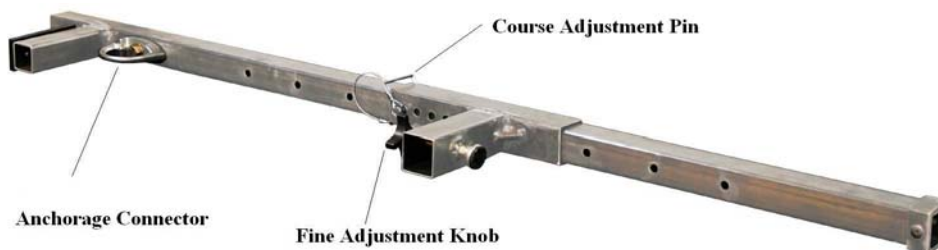

INSTALLATION: The Door Jamb Anchor may be installed in any door or window opening meeting the requirements specified for size and strength. **DO NOT USE ANCHOR IF OPENING IS LARGER OR SMALLER THAN ALLOWABLE.**

Step 1. Adjust the Door Jamb Anchor to fit inside the desired opening by removing the pin and sliding the adjustable leg toward the D-ring. Make sure the fine adjustment pad is adjusted so that it is tight against the support bar with the threads on the stud showing on the knob side of the steel tubing.

Step 2. Place the Door Jamb Anchor in the door or window opening with the D-ring facing the area where work will be performed. The adjustable leg may be located either on the left or right side of the opening. The Door Jamb Anchor **must** rest on the bottom of the window or door opening. Do not attempt to install the Door Jamb Anchor in a position where it is not supported by the floor or window sill.

Step 3. Slide the adjustable leg as close to the door or window jamb as possible and insert the pin in a corresponding set of adjustment holes. Secure the anchor using the fine adjustment knob by rotating the knob clockwise.

PERSONAL FALL ARREST SYSTEM: Attach the shock absorbing lanyard to the dorsal D ring only of the full body harness. Make sure harness is donned properly for fit.

STRUCTURE: Ensure the structure you will be connecting to is properly supported before using this equipment. Approach the structure using appropriate access equipment.

OTHER CONSIDERATIONS: When working on a structure do not take unnecessary risks, such as jumping or reaching too far from the edge. Be aware of all environmental hazards in the area. Do not allow your connecting subsystem to pass under your arms or between your feet. To avoid inadequate fall clearance, do not climb above or to the side of the Door Jamb Anchor.

- A. SHARP EDGES:** Avoid working where the connecting subsystem (energy absorbing lanyard) or other system components will be in contact with, or abrade against, unprotected sharp edges. If working around sharp edges is unavoidable, protection against cutting **MUST** be provided through the use of protective cover.
- B. IN THE EVENT OF A FALL:** The responsible party must have a rescue plan and the ability to implement a rescue.
- C. RESCUE:** Rescue should be performed in the most timely manner considering all scenarios possible. Training on rescue should be performed on a periodic basis.

Training: It is the responsibility of the user to assure they are familiar with these instructions, and are trained in the correct care and use of this equipment. User must also be aware of the operating characteristics, application limits, and the consequences of improper use of this equipment.

INSPECTION

FREQUENCY: Unit should be inspected before each use and periodically by a competent person other than the user. Inspect the Door Jam Anchor for cracks, dents, bends, corrosion,

or other deformities. Make sure all parts are functioning properly and are not missing. Make sure all adjustment mechanisms are in proper working order. Ensure pin and its locking mechanism work properly. Ensure all labels are present. **If at any time inspection reveals any unsafe conditions, remove from service immediately.**

MAINTENANCE, SERVICING, STORAGE

CLEANING: Periodically clean the Door Jamb Anchor using water and a mild soap solution. Do not use acids or other caustic chemicals that could damage the system components. Store anchor in an environment that will not cause damage to or deterioration of unit.

SPECIFICATIONS

MATERIALS:

All materials used in the construction of this equipment are as follows:

Galvanized Steel Tubing

Zinc-Plated alloy hardware.

Zinc-Plated alloy steel D-ring.

DIMENSIONS AND WEIGHT

Size: Adjustable to fit 20 in. to 50 in. openings.

WEIGHT: 18 lbs.